



EXPANSION JOINTS FOR NUCLEAR POWER PLANTS



ditec – A POWERFUL PARTNER - FOCUSED ON SOLUTIONS

Through specialisation, our company has positioned itself as a worldwide leading manufacturer of rubber and textile expansion joints. As a developer and manufacturer, we focus on our customers' demands. We make the seemingly impossible possible – with a high degree of technical expertise and commitment, combined with decades of experience. We rise to every challenge.

In our state-of-the-art production plant in Kitzingen, we produce tailor-made solutions and serial items. Each fabric expansion joint is individually designed. Even when the specific requirements in terms of operating parameters vary only slightly, it is only by taking these into account accurately that a long service life and failure-free use of your expansion joint solution can be guaranteed.

Just describe your needs to us, and we will provide you with personalised advice. With your project team, we develop an efficient solution for you - both in the field of standard devices and for special applications - with our characteristic combination of know-how, innovation and flexibility.

You can rely on your order to be processed rapidly and on schedule – even if it is urgent. We provide support not only as a supplier, but also as problem solvers.

This catalogue provides you with an overview of our product range and an invaluable base of technical details and planning tools.



ditec®

ditec – INNOVATION - MADE IN GERMANY

On a site extending to 17,600 m², we produce all expansion joints in the same place where we develop them. Our commitment to our German production location forms the core of our philosophy, which privileges the very highest quality above all else. Thanks to the high degree of vertical integration in our own product plant, we achieve highly efficient production processes.

Our design of models puts us in a position to respond rapidly to orders at extremely short notice, and to produce single pieces as well.

We have our own calendar plant and our own appropriately dimensioned vulcanisation plants. A metalworking company directly integrated in the production plant manufactures all the steel accessories we require. This concentration in a single location is evident: we are able to make all the essential components in-house and are therefore largely independent of vendors.



ditec – A FAMILY COMPANY

Established in 1973 in Kitzingen by Manfred Adam, the high-tech company is now managed in the second generation by siblings Gabriele and Christoph Adam. The ditec team currently numbers some 85 employees – meaning that their ranks have more than quadrupled over the past two decades. What remains unchanged is the spirit of cooperation and partnership within the family-owned business. The team spirit and concentrated know-how of our employees are the hallmarks of ditec.

Without the experience and sense of responsibility of every individual, a true manufacturing business like ours would be inconceivable. After all, we literally work hand-in-hand here.



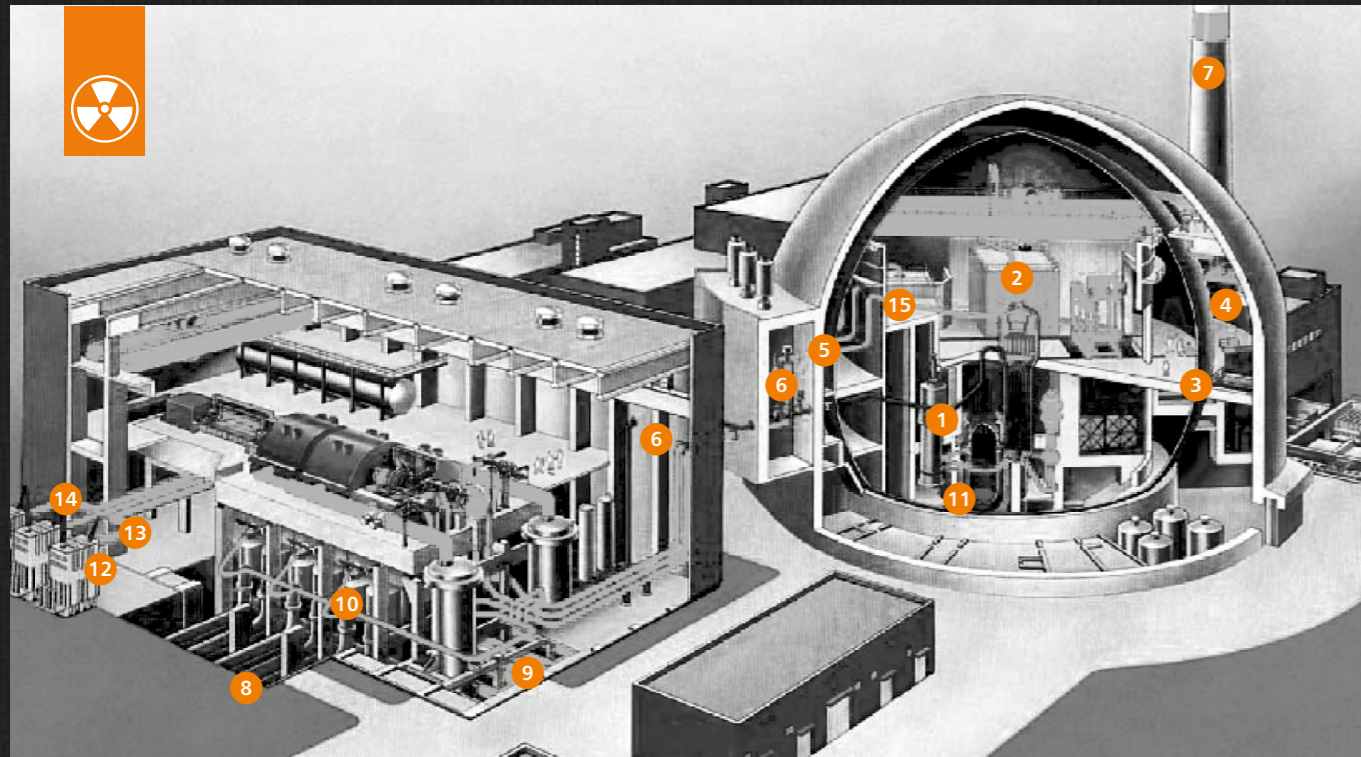

Application examples for the PRESSURIZED-WATER REACTOR

- 1 Seal between base plate and wall for the reactor pool and spent fuel pool
- 2 Flexible seal between steam generator head and equalizing ceiling as well as between equalizing ceiling and wall
- 3 Expansion joint between personnel or material sluice and reactor containment
- 4 Compensators between air fan and ducts of the air conditioning system
- 5 Superstructure of corroded metal expansion joints with rubber bellows as provisional seal between steam pipeline penetration through the reactor containment
- 6 Airtight, splash water and fire protection penetrations seal for walls and floors
- 7 Flexible joint between air conditioning ducts and exhaust stack
- 8 Rubber expansion joints for cooling water pipelines
- 9 Ground water seal
- 10 Dog-Bone expansion joint between turbine neck and condenser
- 11 Inflatable seal between polygon and reactor during change of nuclear fuel rods
- 12 Flexible seal for GIS pipes
- 13 Casing expansion joints for the switch gear
- 14 Leaktight penetration seal against weathering
- 15 Watertight inner joints to seal between floor and reactor containment

Material

Each expansion joint or seal is individually designed according medium, pressure, temperature and movement.

1st stage: made from a selection of rubber we calender foils, coat fabrics and manufacture individually each expansion joint and seal.

2nd stage: vulcanization and annealing, this guarantees:

- the absolute resistance to pressure and thermal deformation
- elasticity increase of the joint
- and high mechanical strength

Especially for the application within the reactor containment we are working with a silicone rubber which was exclusively developed for ditec. This rubber fulfills following properties:

- Lifetime up to 40 years
- Radiation resistance

Following a dose of 200 kGy from ionised radiation the rubber elasticity remains to 200 %

- Free of halogens
- Permanent temperature resistance up to 200°C
- Decontamination possible
- Nekeal gastight

Accessories as backing flanges, flow liner and support rings are made of C-steel and all standard grades of stainless steel.

We hold at present a complete range of third party approvals from all honoured nuclear establishments.

Quality Management

Our quality management system is certified according DIN EN ISO 9001:2015 and we hold the nuclear certification according to KTA 1401 and IAEA 50-C-Q.

All expansion joints fully conform the pressure equipment directive PED 2014/68/EC and we are also authorized to offer CE-marking. For fabrication of all accessories we also hold the welding certification according to DIN EN ISO 3834-3 and DIN EN 1090-2.

Our inhouse quality system ensures that we are able to offer the preparation of construction plans.

According to requirements all inspections and hydraulic tests are performed in our work shop.

All technicians and field fitters have the permission for entrance in nuclear power plants and make design and measurement work on site.

ditec is also able to offer complete installation services and our staff is highly trained in the expertize installing and repairing in nuclear plant equipment.



Pipe Penetration Seal

Movement: 

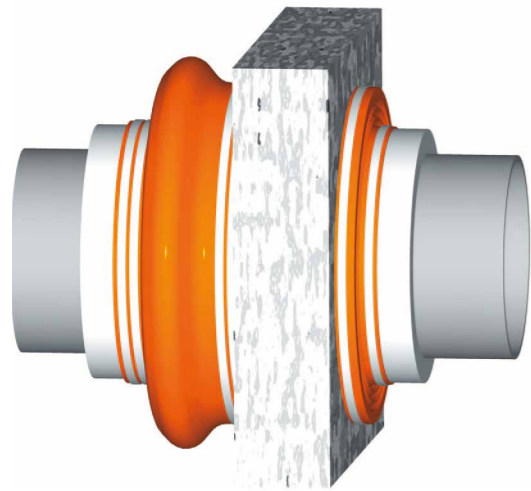

Design features:

- Diaphragms and multiple arch expansion joints
- Individually designed according medium, temperature and pressure
- With flanges or clamping bands
- Also with lap joint for installation onto existing pipe penetrations
- For cold water pipes with steam barrier
- Multiple pipe installations in one wall tube possible

Air tight and splash water seal

- Single sided seal on wall or ceiling
- Short installation length

Fire protection R120

- Tested at MPA Braunschweig according to EN 1366-3
- Double sided seal on wall or ceiling is always required

Application examples: 6 14

- Wall or ceiling penetrations of pipelines

Dimensions:

- Medium and wall tube diameter variable, all combinations possible



Ground Water Seal

Movement: 

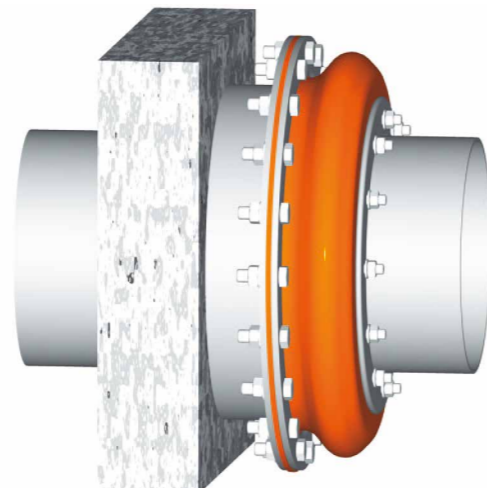

Design features:

- Single or multiple arch expansion joints
- Individually designed according temperature and pressure
- With flanges or clamping bands
- TÜV-test certificates available
- Also with lap joint for installation onto existing pipe penetrations

Application examples: 9

- Penetration seal for buried pipes
- Flood protection of pump stations, valve pit and turbine house

Dimensions:

- Nominal sizes up to ø 4000 mm
- Installation length variable
- We are able to produce to bespoke requirements



Expansion joint between personnel or material sluice and reactor containment

Movement: 

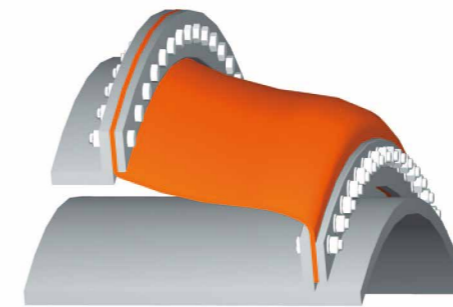

Design features:

- Individually designed according temperature and pressure
- With full face flanges
- Fire resistant fabric inserts against flame-transmission
- Also with lap joint for installation onto existing steel structures

Application examples: 3

- Penetration of sluice casing through reactor containment
- For material, personnel, emergency and auxiliary sluice

Dimensions:

- All cross sections and dimensions
- We are able to produce to bespoke requirements



Expansion joint between steam generator head and equalizing ceiling

Movement: 



Design features:

- Individually designed according temperature and pressure
- With full face flanges
- Also with lap joint for installation onto existing steel structures

Application examples: 2

- Penetration seal between steam generator head and equalizing ceiling
- Flexible seal between equalizing ceiling and reactor containment wall

Dimensions:

- All cross sections and dimensions
- Installation length variable
- We are able to produce to bespoke requirements

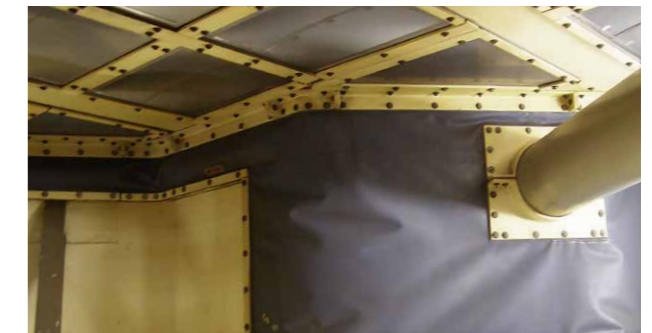

Rubber expansion joint for cooling water pipelines

Movement:

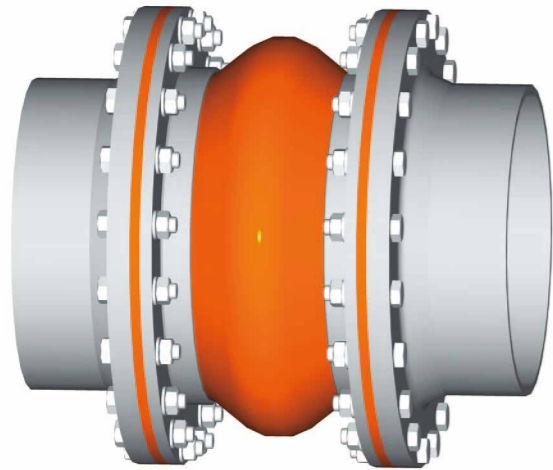

Design features:

- Single or multiple arch expansion joints
- Universal joint or lateral expansion joints with tie rods to carry the reaction forces of the bellow
- Individually designed according medium, temperature and pressure
- With full face flanges or sealing bulge with swivel steel backing flanges

Application examples: 8

- Cooling water pipelines in power plant technology
- Flexible joint at condensers
- Suction and discharge side on pumps

Dimensions:

- Nominal sizes up to \varnothing 4000 mm
- Installation length variable
- We are able to produce to bespoke requirements



Expansion joint for air conditioning system

Movement:

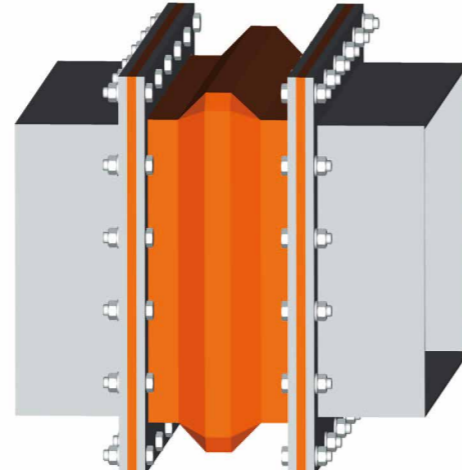

Design features:

- Single or multiple arch expansion joints
- Individually designed according temperature and pressure
- With full face flanges
- Also with lap joint for installation onto existing pipework

Application examples: 4 5 7

- Suction and discharge side of fans, at quick action stop valves and exhaust chimney, in the DAS-System
- In ducts to compensate expansions, to absorb movement from earthquake and building settlements
- In smoke exhaust ducts for 600°C during 120 minutes

Dimensions:

- Round, rectangular or oval cross sections, all dimensions
- Installation length variable
- We are able to produce to bespoke requirements



“Dog-Bone”-expansion joint between turbine neck and condenser

Movement:

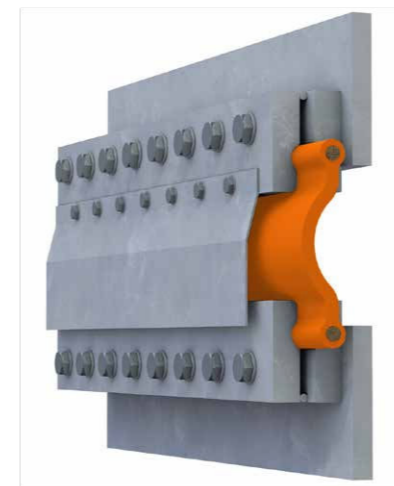

Design features:

- Belt expansion joints made of rubber
- Dog-Bone moulded fixing geometry
- Also with lap joint for installation onto existing steel structures
- Media: water, steam, air
- Temperature: up to 120°C
- Pressure: +/- 1 bar
- Movement: axial compression max. 30 mm
axial extension 5 mm
lateral offset max. 16 mm

Application examples: 10

- Between turbine neck and condenser

Dimensions:

- Belt length individually manufactured



Flexible seal Inner Joints

Movement:



Design features:

- Rubber moulded parts individually manufactured
- We can design and construct to bespoke and to clients specifications

Application examples: 1 2 11

- Sealing between base plate and wall for the reactor pool and spent fuel pool
- Trim seal around the exhaust and air ducts as well as at the plugboard and pit
- Inflatable seal between polygon and reactor during change of nuclear fuel rods
- Watertight inner joint to seal between floor and reactor containment
- Gasket between any kind of flange connection

Dimensions:

- Individual design





ditec-adam.de

ditec Dichtungstechnik GmbH

An der Staustufe 6

97318 Kitzingen | Germany

phone: +49 9321 2307 0

fax: +49 9321 2307 28

www.ditec-adam.de

info@ditec-adam.de